

Product code | Codice Prodotto

B035-01N

Note

Thank you for purchasing Matest product.
Read this manual carefully for a correct machine/equipment functioning.

In case of sale, the manual and its enclosures should be given to the new owner.

For further information contact your authorized distributor or Matest at

info@matest.com

Note

Vi ringraziamo per aver acquistato un prodotto Matest.

Per garantire il funzionamento ottimale della macchina/attrezzatura, Vi preghiamo di leggere attentamente questo manuale d'istruzioni.

In caso di vendita, il presente manuale ed i suoi allegati devono essere consegnati al nuovo proprietario.

Per ulteriori informazioni contattate il rivenditore autorizzato a Voi più vicino o scrivete a

info@matest.com

Indonesian Exclusive Authorized Distributor

INDOTEST
MATERIAL TESTING EQUIPMENT



INSTRUCTION MANUAL

"AUTOMATIC MARSHALL COMPACTOR FOR 4" AND 6" MOULDS"

MANUAL CODE

B035-01N

Do not attempt to operate this equipment before reading
and comprehending the manual in all its parts

Instruction Manual

AUTOMATIC MARSHALL COMPACTOR FOR 4" AND 6" MOULDS

Product Code

B035-01N

Do not attempt to operate this equipment before reading
and comprehending the manual in all its parts

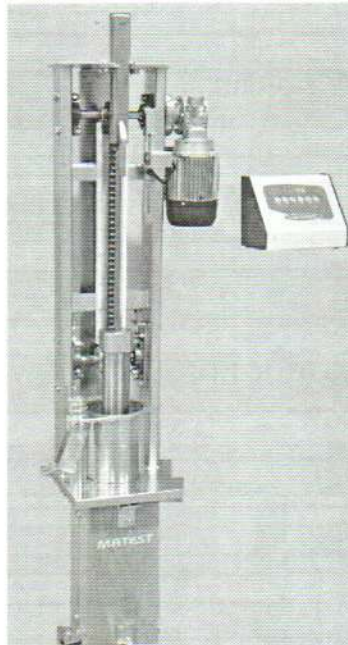

Users

MACHINE MANUFACTURERS | DRAUGHTSMEN | OPERATORS | MAINTENANCE WORKERS | ANY OTHERS

REV.	DESCRIPTION	MANAGED	APPROVED	PRODUCT CODE	PAGES	ISSUE DATE
01	Instruction Manual	Technical Office	Tech Manager	B035-01N.M01.EN01	25	10/2015

GENERAL INDEX

Chapter 1		GENERAL INFORMATION	
1.1	Warnings	1.8	Machine Identification Data
1.2	WARNING and DANGER indications - SIGNS	1.9	EC Stamp
1.3	Aim of the Instructions Manual	1.10	Usage
1.4	Structure of the Instructions Manual	1.11	Operators
1.5	Composition of the Instructions Manual	1.12	Storage
1.6	Modifications and enclosures of the Instructions Manual	1.13	Transportation and Movement
1.7	Constructor Identification	1.14	Packaging removal

Chapter 2		TECHNICAL CHARACTERISTICS	
2.1	General machine description		
2.2	Dimension and weight		
2.3	Electrical supply		
2.4	Noise		

Chapter 3		GENERAL SAFETY NORMS	
3.1	General norms		
3.2	Machine Safety devices and protection		
3.3	Passive safety devices		
3.4	Active safety devices		

Chapter 4		INSTALLATION INSTRUCTIONS	
4.1	Location		
4.2	Handling and movement		
4.3	Assembling procedure		
4.4	Electrical connection		

Chapter 5		MAN-COMMAND INTERFACE	
5.1	Workplace		
5.2	Commands and signals		
5.3	Meters – Indicators		
5.4	How to operate		

Chapter 6		MACHINE REGULATION AND TUNING	
6.1	Regulations		
6.2	Checking the safety devices work		

Chapter 7	IN FUNCTION - USE
7.1	Machine calibration – Meters - Indicators
7.2	Switching on the equipment
7.3	Equipping – Sample positioning
7.4	Programming the control panel
7.5	Procedure for the opening of the safety guards
7.6	Emergency stop
7.7	Start up after emergency
7.8	Stop commanded by Safety circuit
7.9	Switching off the appliance
7.10	Trial starting
7.11	Example of operating

Chapter 8	MAINTENANCE
8.1	Periodical checks
8.2	Ordinary Maintenance
8.3	Extraordinary Maintenance
8.4	Authorised maintenance centres

Chapter 9	GUIDE TO RECOGNISING DAMAGE AND ANOMALIES
------------------	--

Chapter 10	SPARE PARTS
-------------------	--------------------

Chapter 11	INACTIVITY
-------------------	-------------------

Chapter 12	DECOMMISSIONING THE MACHINE
-------------------	------------------------------------

File	CONTROL PANEL
-------------	----------------------

Chapter 1 GENERAL INFORMATION

1.1 WARNINGS

The manufacturer does not accept any responsibility for direct or indirect damage to people, things or animals and use of the appliance in different conditions from those foreseen.

The manufacturer reserves the right to make changes to the documentary information or to the appliance without advance notice.

Check the machine responds to the standards in force in the state in which it has been installed.

All operations necessary for maintaining machine efficiency before and throughout use are the operator's responsibility

Carefully read the entire manual before operating the machine.

It is vital to know the information and limitations contained in this manual for correct machine use by the operator.

Interventions are only permitted if the operator is accordingly competent and trained.

The operator must be knowledgeable about machine operations and mechanisms.



The purchaser must ensure that operators are trained and aware of all the information and clarifications in the supplied documentation. Even with such certainty the operator or user must be informed and therefore aware of potential risks when operating the machine. Safety, reliability and optimum performance is guaranteed when using original parts.

Any tampering or modifying of the appliance (electrical, mechanical or other) which has not been previously authorised in writing by the manufacturer is considered abusive and disclaims the constructor from any responsibility for any resulting damage. All necessary operations to maintain the efficiency of the machine before and throughout use are the responsibility of the user.

1.2 WARNING AND DANGER INDICATIONS - SIGNS

The machine has been designed and constructed according to the current norms and consequently with mechanical and electrical safety devices designed to protect the operator or user from possible physical damage. Residual risks during use or in some intervention procedures on the device are however present. Such risks can be reduced by carefully following manual procedures, using the suggested individual protection devices and respecting the legal and safety norms in force.

This manual includes "Warning" and "Danger" indications in relevant chapters. These indications are shown with the words "Danger" or "Warning" in bold font and uppercase to make them highly visible.

 WARNING	Il simbolo viene impiegato per indicare che la non osservanza delle indicazioni prescritte potrebbe causare "Danno allo strumento".
 DANGER	Il simbolo viene impiegato per indicare che la non osservanza delle indicazioni prescritte potrebbe causare "Danno allo strumento e/o infortunio al personale".
 INSTRUCTIONS	indicates the need to consult other documents before performing operations.

"**DANGEROUS ZONE**" indicates any zone inside or in the proximity of the appliance in which a person is exposed to the risk of injury or damage to health.

1.3 AIM OF THE INSTRUCTIONS MANUAL

This manual has been edited with the aim of providing all machine operators with all the necessary information on installation, use and maintenance from production to scrapping in as comprehensive and clear manner as

possible. All the procedures useful for any foreseeable emergency situations have been listed by the manufacturer and can be verified during use.

Operators, for whom this manual has been written, due to their competence must give instructions or operate the machine themselves. The instructions manual must be carefully consulted by laboratory or site safety managers, equipment operators and any internal and external maintenance workers.

The manual is integral to the product and refers to this appliance only.

The manual must be safeguarded and always kept near the equipment so that it can be easily consulted whenever necessary.

IMPORTANT: The manual does not substitute the experience and technical training of the worker but must be considered a guide for carrying out its functions. Furthermore all the norms and rules the operator should be aware of or consult for correct use of the machine and/or test performance can be found in the manual.

This responsibility is entrusted to the installer and Laboratory or Site Manager where the machine is installed.

The Constructor is available to provide further information.

1.4 STRUCTURE OF THE INSTRUCTIONS MANUAL

The manual can consist of a number of documents, as shown in the appropriate list.

Verify that all documents are present; otherwise request the missing parts from the Constructor before using the machine. Instructions can be supplied with enclosures containing diagrams and designs, which are necessary for interpretation of correct machine use and maintenance.

1.5 COMPOSITION OF THE INSTRUCTIONS MANUAL

Description document	Instruction manual code
INSTRUCTIONS MANUAL	B026N.M01

1.6 MODIFICATIONS AND ENCLOSURES OF THE INSTRUCTIONS MANUAL

If this manual reflects the state at the time of the launch of the machine on its market. If any modifications, improvements or adjustments have been made since machine supply the Manufacturer does not have to intervene on the marketed machine and will not consider the machine or the manual deficient or inadequate.

1.7 CONSTRUCTOR IDENTIFICATION

See the front page headline

1.8 MACHINE IDENTIFICATION DATA

On the identification nameplate of the machine are reported the identification data and the electrical characteristics.

1.9 EC STAMP

SEE EC DECLARATION

1.10 USAGE

The automatic Marshall compactor has been studied for the compaction of Marshall specimens. The equipment is made for the aim, which it has been conceived for. Any other uses are not allowed.

1.11 OPERATORS

 DANGER WARNING	The use, transportation, installation, maintenance, demolition and disposal of the appliance are only permitted to "QUALIFIED PERSONNEL". This manual is exclusively aimed at "QUALIFIED PERSONNEL" and contains the necessary information for machine use.
---	---

"QUALIFIED PERSONNEL" means people who, due to their training, experience and education, as well as knowledge of the relevant standards, limitations and measures, have been authorised by the "PLANT SAFETY MANAGER" to carry out any necessary activity and are able to recognise and avoid any possible danger.

The manufacturer recommends that the instructions, procedures and recommendations in this manual and the work safety legislation in force be scrupulously adhered to, even with the use of appropriate protection devices (whether individual or part of the machine).

Knowledge and respect of the instructions, safety warnings and danger in this manual are all necessary for installation, operation, management and machine maintenance with a minimal risk.

The "PLANT SAFETY MANAGER" has the following responsibilities and duties:

<ul style="list-style-type: none">- To know the machine functions, its commands, safety and protection devices, possible dangers of use and all the information in this manual in detail. This knowledge can only be gleaned from detailed reading of this manual.	<ul style="list-style-type: none">- Correctly train and educate the "QUALIFIED PERSONNEL" before allowing them access to the machine. The personnel must also be exhaustively trained with regards to the machine's protection devices.
<ul style="list-style-type: none">- To know the safety legislation in force in detail in order to operate the machine- To recognise the "QUALIFIED PERSONNEL" for transportation, handling, installation, use, maintenance, disposal, etc.	<ul style="list-style-type: none">- Ensure the machine's safety devices are not tampered with or removed and are checked on a daily basis. Provide the operator appropriate individual protection devices according to the laws in force.
<ul style="list-style-type: none">- The constructor is available for clarification, assistance and training and declines all responsibility for damage to things or people resulting from improper, incorrect and negligent use by untrained personnel.	

1.12 STORAGE

	WARNING	The appliance must be stored and conserved in the original packaging and in a closed environment, protected from atmospheric agents with a minimum temperature of -15°C , and a maximum of $+60^{\circ}\text{C}$ and a maximum humidity of 70%.
---	----------------	---

1.13 TRANSPORTATION AND MOVEMENT

	WARNING	In order to avoid irreparable machine damage, move with care, do not overturn, protect from rain, do not stack, protect the packaging and its contents from bumps and sources of heat.
---	----------------	--

Machine transportation and movement must be entrusted to Qualified Personnel who can ensure correct movement. The machine is equipped of two steel eyebolts. (top side).

	DANGER WARNING	Do not transport or move the product should it be impossible to respect the conditions on the packaging or there be any doubts. Request information from the constructor.
---	---------------------------	---

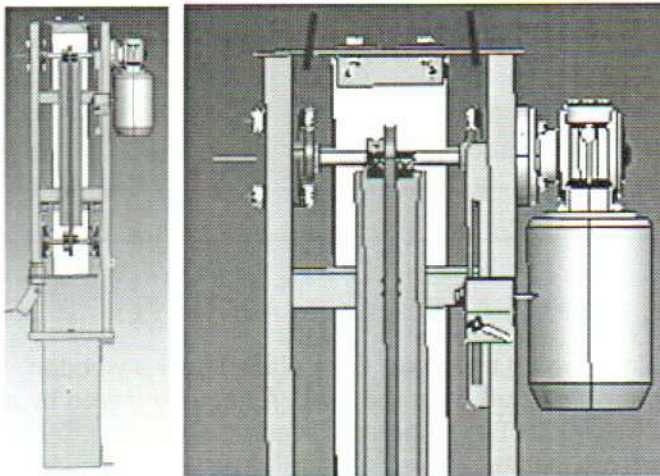

THE MACHINE MUST BE SUBMITTED WITH THE ROPES AS SHOWN IN PICTURE NEXT.

MINIMUM LENGTH ROPE = 1m

MACHINE NET WEIGHT: 105 Kg ~

1.14 PACKAGING REMOVAL

After removing the packaging check the machine is complete and that there are no visibly damaged parts. DO NOT USE THE MACHINE and refer to the constructor when in doubt.

	DANGER	The components used for packaging (plastic bags, polystyrene, nails, screws, wood, etc) must
be kept out of reach of children, as they are sources of danger. These components should be placed in the appropriate containers.		

	WARNING	In order to avoid bumps and overturn adopt the normal and logical precautions.
---	----------------	--

	WARNING	Before disposing of the packaging check all machine components such as accessories, utensils, instructions, documents etc have been removed.
--	----------------	--

Chapter 2 TECHNICAL CHARACTERISTICS

2.1 GENERAL MACHINE DESCRIPTION

Two main parts form the appliance:

- **THE COMPACTOR (ENCLOSURE A)** is mainly formed by a steel base placed over a wooden pedestal. A mould housing the specimen is located upon the base. A hammer driven by a trip mechanism provides specimen compaction. The hammer is lifted to a height of 457,2 mm and allowed to fall free at 64 blows per minute.
- **THE CONTROL PANEL (ENCLOSURE B)**. It allows controlling and managing the compactor functions. Consult the enclosed file for further details.

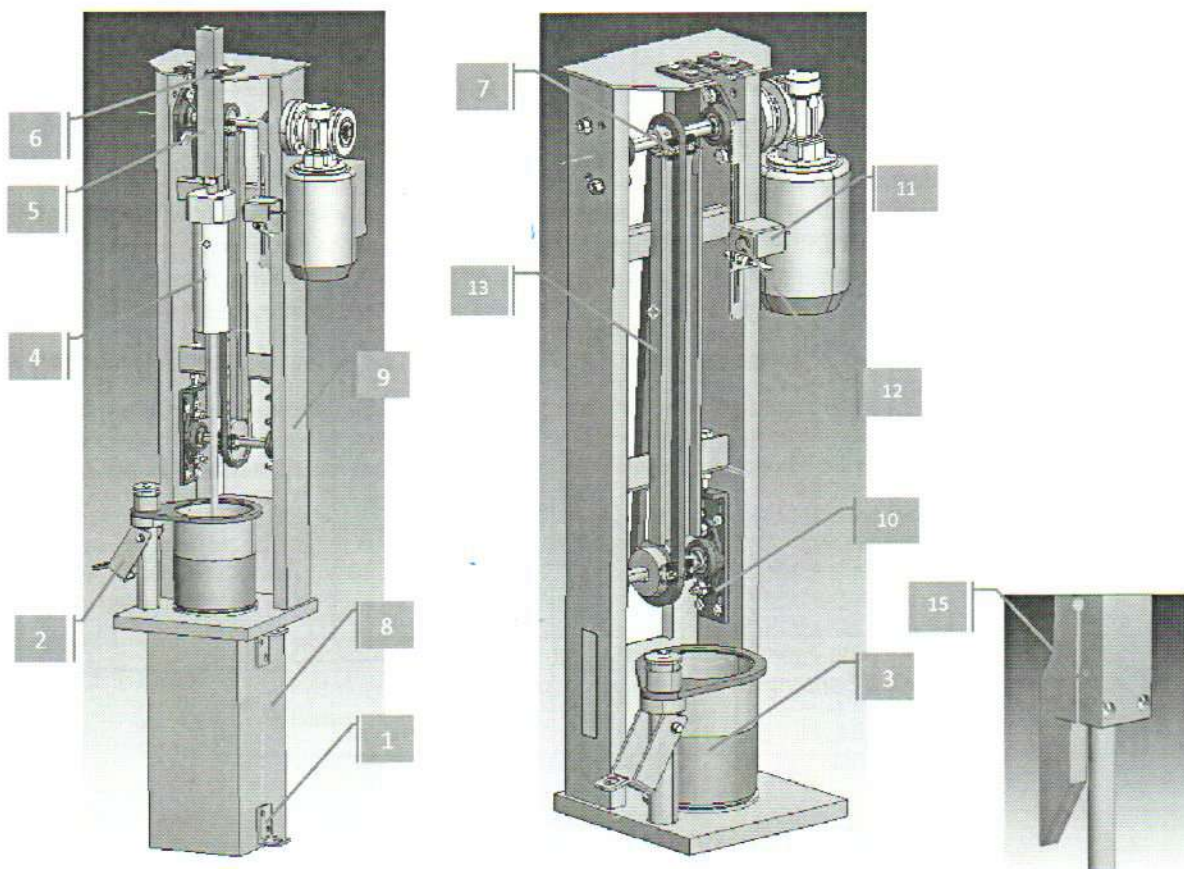

RIF.	DESCRIZIONE	RIF.	DESCRIZIONE
1	FIXING BRACKETS	8	PEDESTAL
2	LEVER FOR MOULD BLOCKING	9	FRAME
3	MOULDS	10	CHAIN TENSIONER
4	COMPACTION HAMMER	11	SENSOR BRACKET
5	GRIP HANDLE	12	LOCKING BRACKET
6	HAMMER GUIDE	13	CHAIN GUIDE
7	HOOK	14	SENSOR
		15	REGULATION SCREWS

2.2 DIMENSIONS AND WEIGHT

	B035-01N
LENGTH	540 mm
WIDTH	400 mm
HEIGHT	1600 mm
WEIGHT	105 kg

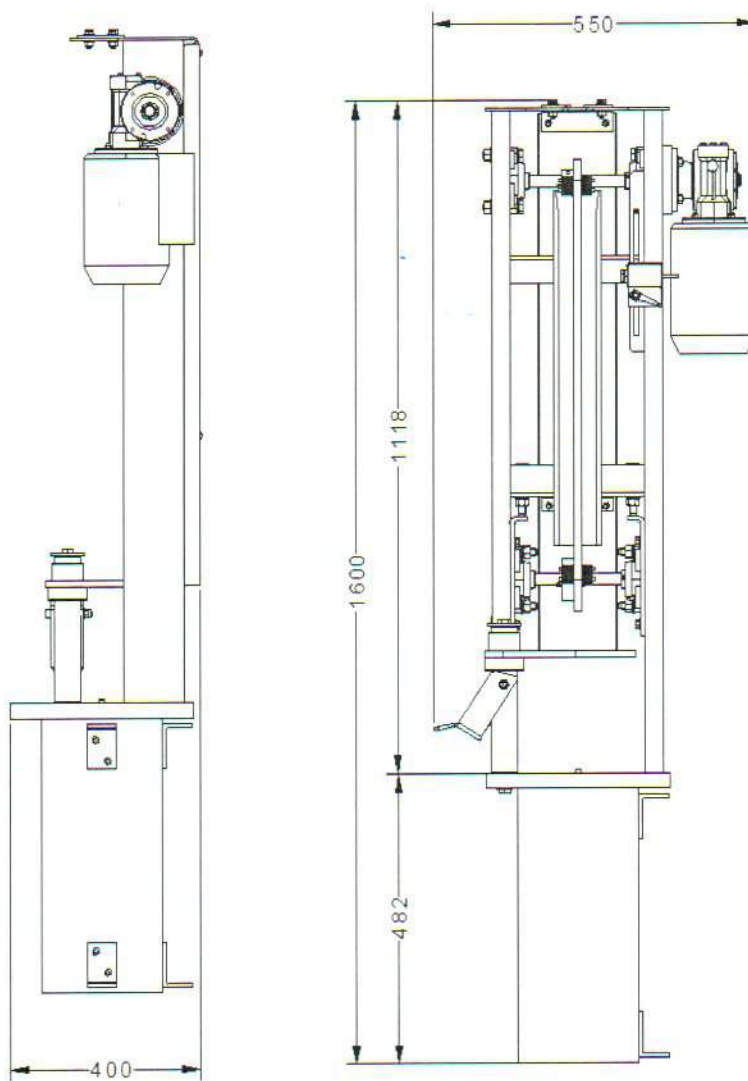

2.3 POWER SUPPLY

On the nameplate located on the machine shows the complete identification data and electrical characteristics.

2.4 NOISE

The emission levels of airborne noise listed below do not necessarily safe exposure levels for workers. The exposure levels of workers are obviously related to the emission levels of the instrument; However, other factors also influence the levels of worker exposure: duration of exposure, characteristics of the environment, the presence of other machines and so on. The emission levels of the instrument permit, however, to make an estimate of the hazards due to noise.

The air noise emission levels shown do not necessarily imply the levels of exposure to the worker.

The levels of exposure to the operator are obviously linked to the emission levels of the appliance; however other factors influence the levels of exposure to the operator: length of exposure, environmental characteristics, the presence of other machines etc. The appliance emission levels allow anyway an estimate to be carried out on the dangers due to noise.

If the daily personal exposure is equal to or more than 85 dB (A) it is advisable to use the Individual Protection Devices (protective headphones, plugs, etc.). If the daily personal exposure is equal to or more than 90 dB (A) it is compulsory to use Individual Protection Devices (protective headphones, plugs, etc.). For further information consult the standards in force in the country of installation.



DANGER

Continuous use of the appliance and machines predictably present in the installation environment could cause a heightened daily personal exposure to noise.

Chapter 3 GENERAL SAFETY STANDARDS

3.1 GENERAL STANDARDS

To ensure the safety of machine operators:

<ul style="list-style-type: none"> Any tampering with the appliance not pre-emptively authorised by the manufacturer exempts the manufacturer from any responsibility for damage caused by or to it. The removal or tampering with safety devices entails a violation of the safety standards. Machine use is only allowed in areas where there is no risk of explosions or fires. Only the original fittings can be used. The use of unoriginal fittings exonerates the manufacturer from all responsibility. Check the appliance is in ideal working conditions and that its parts are not worn or faulty before Carry out all necessary maintenance Do not wear loose clothing, ties, chains or anything else which could become caught in the frame or other moving parts of the appliance. 	<ul style="list-style-type: none"> Be aware of the danger of electrical shocks from direct or indirect contact due to unforeseen electrical faults. Do not subject the appliance to violent impact. Do not expose the appliance to fire, welding sparks or extreme temperatures. Do not bring the appliance into contact with corrosive substances. Do not wash the appliance with jets of water. <p>Check the workspace around the machine is clear from potentially dangerous objects.</p> <p>The machine operator must wear appropriate work clothing such as protective glasses, gloves and mask in order to avoid damage from, for example, harmful dust projection. Wear a lower back support when lifting heavy parts.</p> <p>There should be no hanging objects such as bracelets or otherwise, long hair should be protected with relevant precautions, shoes must be appropriate for the type of operation to be carried out.</p> <div style="text-align: center;"> </div>
---	---

DURING USE

When operating check there are no conditions of danger. Immediately stop the machine when it is functioning irregularly. Contact the authorised Sales Service department.

- For the operator's safety do not touch any part of the appliance when testing and use the appropriate individual protection devices in order to keep the operator safe.

RISK OR DANGER		PROTECTION DEVICES	
FINGER SQUEEZE CUTS OR ABRASIONS		REINFORCED GLOVES	
MATERIAL FALL		ACCIDENT-PREVENTION SHOES	

3.2 Machine Safety devices and protection

DANGER	<p>Tampering with the guards or any modification of the instrument may cause risks to users and to exposed persons.</p> <p>The manufacturer assumes no liability for direct or indirect damages to persons, property or pets or not, resulting from the tampering of the protections.</p>
---------------	---

The testing machine is supplied in two versions:

- The STANDARD version where no safety devices are foreseen.

- The EUROPEAN CE version where a safety micro is foreseen. This enables the access to the moving parts during the test execution.

3.3 Passive safety devices

For passive safety devices are meant all those devices avoiding or reducing the risks for the operators. These devices don't require any intervention to be operated.

On the Compactor, supplied with safety guards, you can find a protection micro switch that stops the machine functioning whenever the carter is not closed correctly or it is opened during the test running.

3.4 Active safety devices

For active safety devices are meant all those devices avoiding or reducing the risks for the operators. These devices require an active and aware intervention to be operated.

On the control panel there's a Main Switch also acting as safety switch

Chapter 4 INSTALLATION INSTRUCTIONS

4.1 LOCATION

The equipment must be placed in an ideal position and environment for the use it has been conceived for (laboratory use and protected from atmospheric agents) and that the machine is placed by a qualified operator.

ALLOWED TEMPERATURE:

+5°C / +40°C

ALLOWED RELATIVE HUMIDITY:

30% / 70%

MAXIMUM HEIGHT OVER SEA

LEVEL: 1000 m

GENERAL ADVICE

- The machine must be installed in an area which allows ease of access to all parts so that maintenance may be carried out.
- Unauthorised people and objects which could be potential sources of danger must not be permitted in the area surrounding the machine.

Do not position the equipment near instruments or appliances which could produce vibrations.

EN Standard requires the machine to be rigidly mounted on a firm and level concrete base. The levelling foot supplied are considered acceptable for mounting on any firm and rigid level surface

4.2 TRANSPORTATION AND MOVEMENT

These instructions are applicable to the machine assemblers. Ensure the equipment is correctly supported at the lifting point and that the machine does not slip. Do not remain in direct line with the application of force and do not allow personnel where there are loads that cannot be adequately supported by mechanical means.

4.3 ASSEMBLING PROCEDURE

After removing the package, check that any parts of the machine are not damaged. In case of doubt, DO NOT USE THE MACHINE and ask the manufacturer.

4.4 ELECTRICAL CONNECTION

Wiring of the electrical system must be carried out by qualified personnel.



DANGER

Before wiring consult the electric plan linked to the instructions manual and the registration plate on the machine for information regarding supply, frequency and nominal current. Connect the earthing system via the PE terminal (yellow-green) before any other connection.

Apply a knife switch at the top of the connecting cable of the machine to the power system.

The knife switch must be combined with a safety device against the overload with a differential switch (safety switch). The technical features of the safety device must be in accordance with the standards in force in the country where the machine has been installed.

ELECTRIC TOLERANCES:

- Real voltage $\pm 10\%$ of the nominal one
- Frequency: $\pm 1\%$ of the nominal one in a continuous way
 $\pm 2\%$ of the nominal one for a short period
- The harmonic distortion of the sum from the second to the fifth harmonics not more than 10% of the total voltage as a real value between the conductors. A further distortion of 2% is accepted for the sum from the sixth to the thirtieth harmonics of the real total value between the conductors.
- With reference to the voltage imbalance of the three-phase voltage, the inverted sequence component and the zero sequence component must not be more than 2% of the direct sequence component of the voltage.

- The voltage pulses must not last more than $1,5$ ms with an up/down time between 500 ms and 500 ms and a peak value not higher than 200% of the real value of the nominal tension.
- The electric supply must not be interrupted or zeroed for more than 3 ms at any time. Between two interruptions it must not take more than 1 s.
- The interruptions must not overcome 20% of the tension peak for more than one cycle. Between two interruptions it must not take more than 1 s.

The manufacturer assumes no liability for any damages to people, things and animals caused by the non-compliance of the above instructions.

CHAPTER 5 | MAN-COMMAND INTERFACE

5.1 | WORKPLACE

The machine is designed to be used by an operator. During normal use of the machine, the work area is to the front side.

5.2 | COMMAND AND SIGNALS

For the correct set up of the control panel, consult the file enclosed to this manual.

5.3 | METERS-INDICATION

The machine is equipped with a photoelectric sensor, which allows to record the falls of the hammer.

5.04 COMPACTION HAMMER (OPTIONAL)

The machine can be configured with compaction hammer B035-11N (6") or with the compaction hammer B035-12N (4").

During maintenance operations to the mold it may be convenient to lift the pestle by hooking it to the appropriate retainer as shown

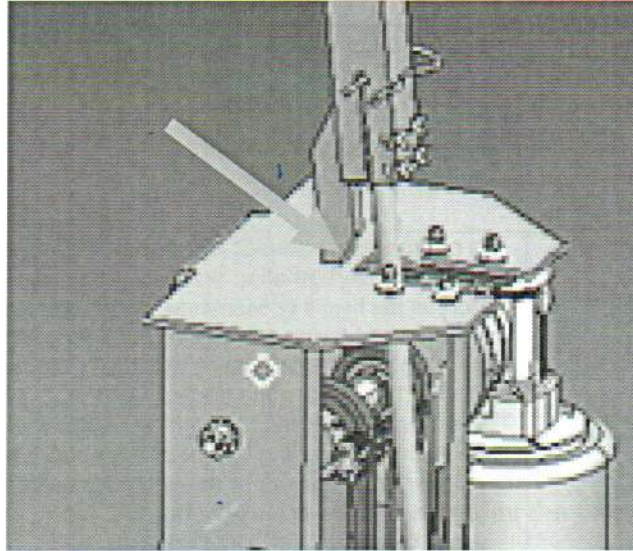

During machine running it is necessary to insert the safety plug as shown in the figure

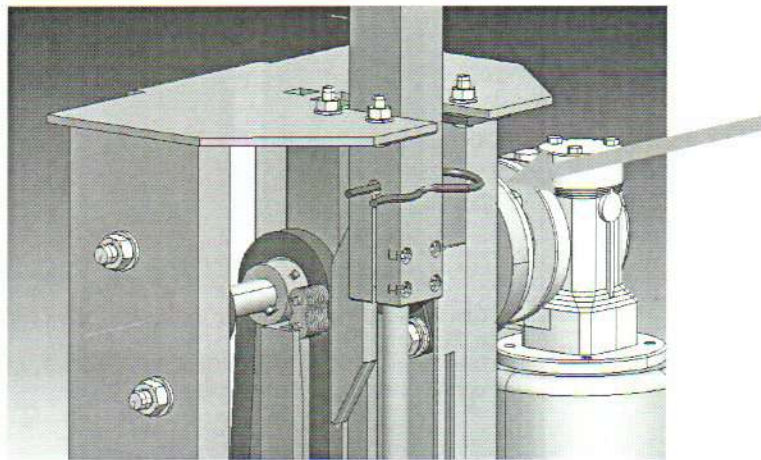

These operations are performed for the first time, must be performed by a qualified person in the presence of the operator in charge (according to EN 292-2 .. Article 5.5 1d).

6.1 REGULATIONS

Photoelectric sensor recording and related positioning

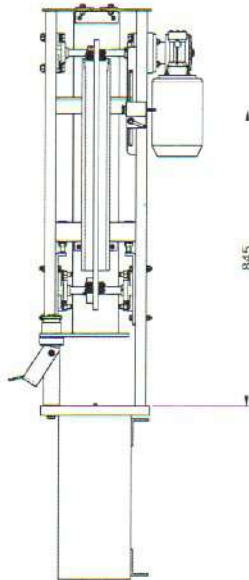

The photoelectric sensor is a device equipped with an emitter, a receiver and a regulation screw. The device is properly adjusted at the factory at the height of 845mm as indicated in the picture, in order to record the number of hammer's passages. In the event of adjustments on the regulation screw, make sure that the recorded and the actually performed blows are the same.

The sensor is secured through two nuts to its support. It is possible to change the positioning height of the sensor holder by adjusting the lock lever. In the event of support's repositioning, make sure that the recorded and the actually performed blows are the same.

Sensitivity adjustment

1. Lift the hitting mass manually so that the sensor may detect it both at the upper square-section and the round section.

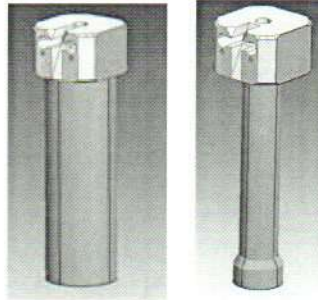

Turn the adjusting screw VR to the position "a" where the LED indicator is ON (Min. Position)

2. Take down the hitting mass so that the sensor may detect only the sliding bar, diameter 16.



Turn the adjusting screw VR up to the position "b" where the led indicator is ON (Max. Position)

3. Place the adjusting screw VR in the middle, between the 2 positions above-named "a" and "b"

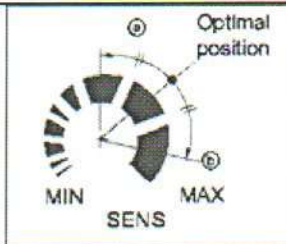

ATTENTION: Once the sensor calibration has been performed, seal the adjusting screw with a drop of silicone.

Height of the falling weight

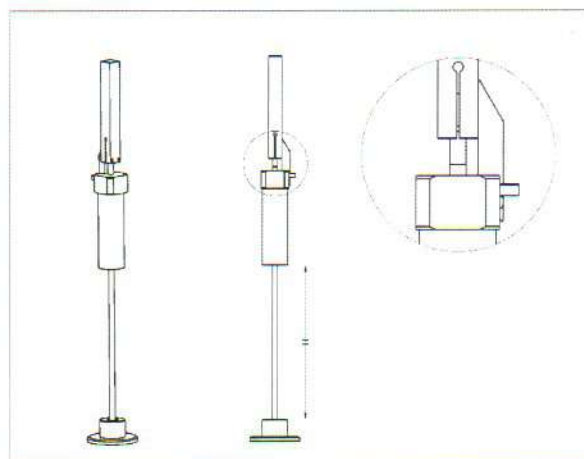

The height of the falling weight is adjusted at the factory.

It is possible to modify the height by acting as shown in the pictures:

- 1- Unscrew the clamping screws,
- 2- Turn the handle clockwise (to decrease the height of the falling height) or turn it counterclockwise (to increase the height of the falling weight)
- 3- Block the clamping screws.

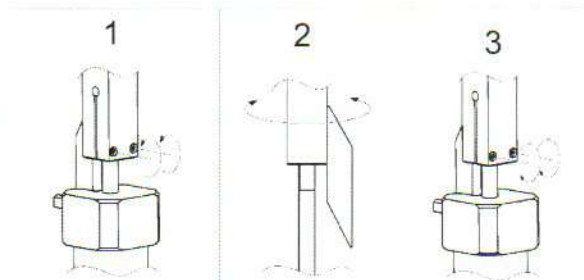

MOLD CENTERING DEVICE (external)

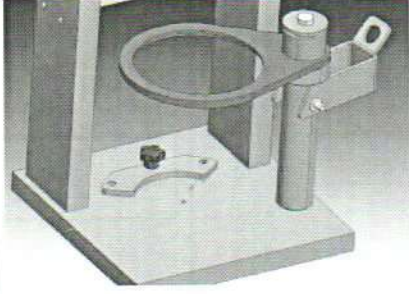
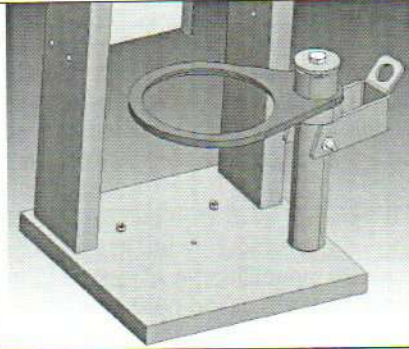
4" Mold use the device in the figure	
6" Mold use the configuration	

MOLD CENTERING DEVICE (CENTRALLY)

it is possible to position the mold using the central hole on compactor base

In this case it is necessary to reverse the screw / grain position on the compactor base (REF. Image above)

6.2 Checking the safety devices work

Before using the tool to verify the correct functioning of the safety devices according to the instructions.

Chapter 7 IN FUNCTION – USE

 DANGER WARNING	Before setting the machine in motion it is essential that the Operator and Safety Manager have read the Instructions Manual and understood all parts of the machine and activities linked to it (Risks, Dangers, Functionality, Operation, Protections, Commands, etc.)
--	---

7.1 MACHINE CALIBRATION – METERS – INDICATORS

The machine is checked in the factory, using sample equipment periodically checked by officially recognised institutes. These checks cannot guarantee that the machine, meters and indicators will provide accurate values and results conforming to the standards in force in the countries the machine has been installed and used in.

Normally such norms envisage calibration check after every movement. In order to obtain correct values and results it is therefore VITAL that the operator, once the machine has been installed and set up and before official tests, has an officially recognised body check the machine characteristics, its calibration and results/values reliability. The manufacturer is exempt from all responsibility in the case of direct and indirect damage from use of the machine without official approval by the relevant bodies.

To switch on the appliance, follow these instructions:

- Put the main switch of the Control Panel on position "I" (for further details consult the file of the control panel enclosed to this manual).

The control panel is configured by the Manufacturer in the stroke-counter mode; in case you realize that the configuration is incorrect and not suitable to the machine features, contact the After Sale Service immediately.

7.3 TOOLING UP

- Open the safety guards;
- Lift the shaft and the hammer;
- Turn the blocking lever so that the mould fixing bracket is lifted;
- Position the mould already filled with the specimen on the centring pin situated on the steel base.
- Turn the blocking lever so that the mould is secured to the base.
- Move downwards the hammer shaft so that the hammer touches the specimen surface;
- Close the safety guards and secure it using the special lever.

7.4 PROGRAMMING THE CONTROL PANEL



For the correct set up of the control panel, consult the file enclosed to this manual.

7.5 PROCEDURE FOR THE OPENING OF THE SAFETY GUARDS

The compactor in EUROPEAN CE version can only work when the safety guard is closed and locked by the special lever.

In case the safety guard is opened during the test running, the Compactor will automatically stop. In this case the stroke number would be lost.

If the operator needs to stop the Compactor at any time and to open the safety guards, he can choose one of these two procedures:

- Pushing the key  the appliance will automatically stop, the stroke counter is reset.
- Pushing the key  the appliance will stop. In this case the preset number of strokes is saved together with the number of strokes made up to then. The key "PAUSE" allows the opening of the safety guards without data loss, so that the test can be continued after the closing of the safety guards.

7.6 EMERGENCY STOP

In case of emergency it is possible to stop the test execution at once by positioning the Main Switch on "0"

ATTENTION

It is worth reminding that the test interruption causes its annulations.

7.7 STARTING AFTER AN EMERGENCY STOP

DANGER

Before switching on the appliance once again, find and solve the problems, which caused the need for an emergency stop.

To switch the appliance again, just move the main switch, placed on the Control Panel, to position "I", this will reset appliance normal functions.

7.8 STOP CONTROLLED BY SAFETY SYSTEMS

If the appliance is provided with safety guards, the test can be interrupted by the safety systems studied to operate in case of malfunctioning. The compactor is equipped with the following safety systems:

STOP CONTROLLED BY THE MICRO SWITCH WHEN OPENING THE SAFETY GUARDS

The safety guard is provided with a protection micro switch to avoid the operator to come in touch with any of the moving parts of the Compactor. If the safety guard is opened while the test is running, the micro switch turns the motor off.

To reset the appliance standard functions it is necessary to close the safety guard.

7.9 SWITCHING OFF THE APPLIANCE

To switch off the appliance, just move the Main Switch to position "0".

7.10 TRIAL STARTING

Before beginning the standard use of this machine, check its perfect working conditions by carrying out at least one complete empty cycle.

In case of problems during this test cycle, see Chapter "DIAGNOSIS".

If neither the instructions given in this manual are not able to solve the problem, please contact our After Sale Service.

7.11 EXAMPLE OF OPERATING

DANGER

Before starting the procedure described hereunder, carefully read and learn the instructions given in this manual.

This machine can be used in different ways depending on the kind of test you wish to perform.

Here follows a "standard procedure" allowing even to an operator without a wide experience to carry out a test. The time will increase the operator's skill in the machine use according to one's need.

1. Switch on the control panel (for further details about the functioning of the control panel, consult the file enclosed to this manual)
2. Tool up correctly the appliance as described in the chapter "TOOLING UP" of this manual.
3. Set up the control panel as described in the chapter "PROGRAMMING" of the file enclosed to this manual.
4. Start the test by pushing the "Start" key, which is on the Control Panel; Consult the file enclosed to this manual.

Chapter 8	MAINTENANCE
------------------	--------------------

8.1	PERIODICAL CHECKS
------------	--------------------------

 DANGER	<p>All maintenance, monitoring and control shall be carried out by professionally qualified and trained on the functions and features of the machine. All operations must be carried out when the machine is switched off and the power cord disconnected physically disconnecting from the power supply. It is allowed to use only original spare parts. The use of non-original parts exempts the manufacturer from any liability.</p>
--	--

OPERATION	CHECK THE HEIGHT OF THE HAMMER FREE FALL
PROCEDURE	SEE "REGULATIONS" CHAPTER
FREQUENCY	AFTER 50 WORKING HOURS

OPERATION	CHECK THE OF PUSH SPRING PINS ON THE HAMMER
PROCEDURE	Press the coupling pins mounted on the hammer and check they carry out the complete stroke without malfunctions.
FREQUENCY	AFTER 50 WORKING HOURS



OPERATION	CHECK THE CHAIN TENSION
PROCEDURE	<p>Make sure the chain is tensed and both tension screws work.</p> <p>To increase the chain tension, loosen the eight screws that lock the two bearing brackets, screw the two tension screws and then tighten the 8 screws previously loosened.</p>
FREQUENCY	AFTER 50 WORKING HOURS

OPERATION	CHECK THE CHAIN ALIGNMENT
PROCEDURE	<p>Check the chain is correctly centered to the return axis of the hammer and it works properly within the nylon guide.</p> <p>If necessary, proceed with the adjustment by means of the fixing screws of the guide.</p>
FREQUENCY	AFTER 50 WORKING HOURS

OPERAZIONE	CLEAN THE HAMMER
PROCEDURA	Clean the surface of the hammer that must be intercepted by the sensor
FREQUENZA	AFTER EVERY TEST

OPERATION	CHECK THE PROPER WORKING OF THE SAFETY DEVICE CONNECTED TO THE LOWER SAFETY GUARD
PROCEDURE	Let the compactor work for some minutes simulating a test. Open the safety guard. When this is opened push the button to start again the working of the compactor. If the appliance doesn't start any of its functions, the safety system is working properly. If the appliance starts some of its functions stop immediately using the machine and follow the disposal given in the chapter "DIAGNOSIS" of this user manual.
PRECAUTIONS	During this inspection nobody, including the end user can be in the space where the rammer is moving.
FREQUENCY	AFTER 50 WORKING HOURS

OPERATION	CLEAN THE DRIVING SHAFT AND THE TRIP MECHANISM
PROCEDURE	Clean the squared driving shaft and the rammer periodically. ATTENTION Do not grease the squared driving shaft. It must work dry.
FREQUENCY	WEEKLY

OPERATION	CLEAN AND GREASE THE SLIDING DEVICE ASSEMBLED ON THE RAMMER
PROCEDURE	Clean thoroughly and grease using silicon oil –highly fluid- the sliding device.
FREQUENCY	AFTER 50 WORKING HOURS
OPERATION	GREASE THE CHAIN
PROCEDURE	Disassemble the safety guard backwards; verify that the chain is greased and the support link of the leading plate is free to move. If necessary wash thoroughly the chain and grease it.
FREQUENCY	AFTER 50 WORKING HOURS

8.2 PERIODIC CHECKS

	DANGER WARNING	<p>Do not perform maintenance – interventions on the machine, which have not been quoted and described in this instructions manual without first contacting the manufacturer. Periodically clean all machine parts and oil the unpainted parts in order to preserve the machine and its efficiency. Avoid the use of solvents, which damage paint and parts in synthetic material.</p>
---	---------------------------	--

8.3 EXTRAORDINARY MAINTENANCE

For extraordinary maintenance operations refer directly to the Manufacturer.

8.4 AUTHORISED MAINTENANCE CENTRES

For information on the nearest authorised help centre it is essential to contact the manufacturer.



Chapter 9 GUIDE TO RECOGNISING DAMAGE AND ANOMALIES

The appropriately qualified, professional personnel must carry out all the maintenance procedures, check and control, as well as all the repair operations on parts of the machine or the electrical system.

Contact Technical Sales Assistance for any other problem not listed on the previous table or should the malfunctioning persist after the intervention of the operator in accordance with the previously mentioned courses of action.

PROBLEM	POSSIBLE CAUSE	CURE
After having switched on the main switch the compactor doesn't work	No supply	Check the proper connection of the plug to the main supply.
	Damage to the motor	Contact our After Sale Service.
	Damage to the electric supply	Check that the cables and the connections of the electrical supply are not interrupted.
The compactor continues keeping all its functions working even after the lower safety guard has been opened.	Damage to the safety system connected to the safety guard.	Contact our After Sale Service for the proper replacement of the safety micro-switch

Chapter 10 SPARE PARTS

 	WARNING	Only original spare parts can be used.
	DANGER	Use of unoriginal spare parts exempts the manufacturer from all responsibility. Procedures for substitution of spare parts will be provided by the manufacturer along with the part. For spare parts contact the manufacturer's Sales Service department.

Chapter 11 INACTIVITY

Ensure all machine parts are in safe working order before operating it again should the machine be inactive for a long period of time. When in doubt contact the Manufacturer.

Chapter 12 DECOMMISSIONING THE MACHINE

Should it be decided that the machine is to be no longer used, proceed as follows:

- Disconnect the electrical supply network by removing the connecting cable therefore making it unusable.
- Make the potential sources of danger harmless, such as sharp or protruding parts.

- Dismantle the machine; divide it into similar parts and dispose of according to the standards in force

Recycling notice for the disposal of electrical and electronic devices



This symbol, shown on the device or on the package and/or the documentation, suggests that the device should not be disposed together with other home garbage at the end of its life cycle.

To avoid further environment, or health-care damage, caused by the unsuitable disposal of garbage, the user should separate this device from other different types of garbage and recycle it in responsibly to avoid the reuse of material resources. Users must take care at the disposal of the equipment by taking it to the nearest recycling site for appropriate recycling treatment for electrical and electronic devices. Gathering and Recycling deplete devices allow the preservation of natural resources and grant them the adequate treatment by respecting health and environment.

For further information on your local recycling site please contact your local council or city waste treatment department. The developer, as producer of electrical and electronic devices, will provide to finance the recycling and treatment services for deplete devices that will come back through these recycling sites, according to the local statement.

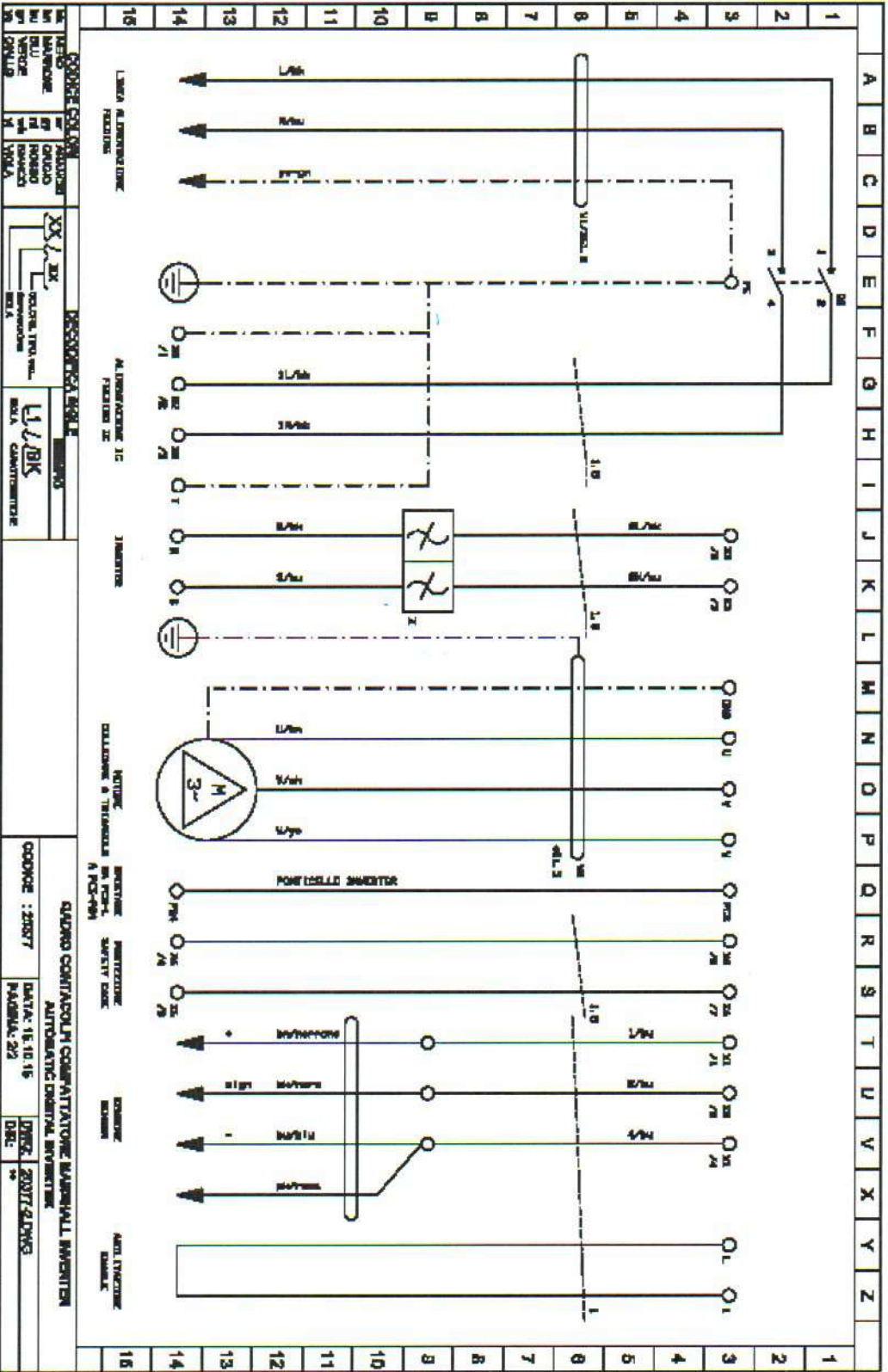

16	15	14	13	12	11	10	9	8	7	6	5	4	3	2	1
----	----	----	----	----	----	----	---	---	---	---	---	---	---	---	---

A	B	C	D	E	F	G	H	I	J	K	L	M	N	O	P	Q	R	S	T	U	V	X	Y	Z
---	---	---	---	---	---	---	---	---	---	---	---	---	---	---	---	---	---	---	---	---	---	---	---	---

16	15	14	13	12	11	10	9	8	7	6	5	4	3	2	1
----	----	----	----	----	----	----	---	---	---	---	---	---	---	---	---

16	15	14	13	12	11	10	9	8	7	6	5	4	3	2	1
----	----	----	----	----	----	----	---	---	---	---	---	---	---	---	---

LUNA ELETTRONICHE
 FUSIONE

ALIMENTAZIONE IC
 FUSIONE IC

MOTORI

MOTORE COLLEGATO A TRIANGOLO
 A PC-99

MOTORE COLLEGATO A STELLA

MOTORE COLLEGATO A STELLA

MOTORE COLLEGATO A STELLA

MOTORE COLLEGATO A STELLA

MOTORE COLLEGATO A STELLA

MOTORE COLLEGATO A STELLA

MOTORE COLLEGATO A STELLA

MOTORE COLLEGATO A STELLA

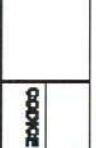

CODICE : 2007
 DATA: 15.10.15
 PIANO: 2/2

DISEGNO: 2007-01-03
 DATA: 15.10.15

DISEGNO: 2007-01-03
 DATA: 15.10.15

DISEGNO: 2007-01-03
 DATA: 15.10.15

DISEGNO: 2007-01-03
 DATA: 15.10.15

DISEGNO: 2007-01-03
 DATA: 15.10.15

DISEGNO: 2007-01-03
 DATA: 15.10.15

DISEGNO: 2007-01-03
 DATA: 15.10.15

DISEGNO: 2007-01-03
 DATA: 15.10.15

DISEGNO: 2007-01-03
 DATA: 15.10.15

DISEGNO: 2007-01-03
 DATA: 15.10.15

DISEGNO: 2007-01-03
 DATA: 15.10.15

DISEGNO: 2007-01-03
 DATA: 15.10.15



Instruction Manual
"CONTROL PANEL"

Product Code
CONTROL PANEL

Do not attempt to operate this equipment before reading
and comprehending the manual in all its parts

Users

MACHINE MANUFACTURERS | DRAUGHTSMEN | OPERATORS | MAINTENANCE WORKERS | ANY OTHERS

REV.	DESCRIPTION	MANAGED	APPROVED	PRODUCT CODE	PAGES	ISSUE DATE
02	Instruction Manual	Technical Office	Tech Manager	COLP.M01.EN.02	08	12/2011

GENERAL INDEX

CHAPTER 1	GENERAL INFORMATION
1.1	GENERAL FEATURES
1.2	IDENTIFICATION
1.3	APPLICATIONS
1.4	DIMENSIONS AND MASS
1.5	STRUCTURE AND OPERATING OF THE MACHINE

CHAPTER 2	OPERATION
2.1	SWITCHING ON OF THE APPLIANCE
2.2	SETTING UP OF THE STROKES NUMBER
2.4	PRACTICAL EXAMPLE OF OPERATING
2.5	CONTROLLED ROTATION FUNCTION (TO ROTATE THE LOS ANGELES CYLINDER INTO THE REQUIRED POSITION)

CHAPTER 3	MAINTENANCE
3.1	SPECIAL MAINTENANCE

TABLES	
D	ELECTRIC PANEL

CHAPTER 1 | GENERAL INFORMATION

1.1 | GENERAL FEATURES

- **This manual is addressed** to the carrier, the installer, the user, the maintenance operator, the scrapping operator.
- Please read it carefully because it informs you about the operating of the machine in safety conditions.
- This manual has to be considered a part of the product and concerns only the machine it is delivered with.
- Keep the manual in order during the whole life of the appliance to consult it for any needs.
- In case of sale, the manual and its enclosures should be given together with the machine.
- The manufacturer assumes no liability for any damages caused by a misuse of the machine.
- The manufacturer has the right to modify this technical literature as well as the machines this refers to without any previous notice.
- Messages meaning:

ATTENTION	It shows the procedures that can damage seriously the machine if they are not followed carefully.
------------------	---

DANGER	It shows the procedures that can be dangerous to the operator if they are not followed carefully.
---------------	---

1.2 | IDENTIFICATION

MANUFACTURER IDENTIFICATION:	See the cover page.
MACHINE IDENTIFICATION:	See the plate on the machine where the complete identification data and the electrical features are to be found.

1.3 | APPLICATIONS

The Stroke Counter Panel has been specially developed to manage electronically the counting of the rotations made by an appliance, or the counting of the minutes from the starting of a test to its end.

The equipment is made for the aim, which it has been conceived for. Any other uses are not allowed.

ATTENTION	The instructions given in this operating manual are only made for the right use of the appliance.
------------------	---

1.4 | DIMENSIONS AND MASS

	STROKE COUNTER PANEL
LENGTH	105 mm
WIDTH	290 mm
HEIGHT	220 mm
MASS	3 kg

1.5	STRUCTURE AND OPERATING OF THE APPLIANCE
------------	---

The Control Panel is formed by (see table D for further info.):

	CONTROL	DESCRIPTION
D1	MAIN SWITCH	To switch on the Control Panel, put it on "1". To switch off the Control Panel, put it on "0".
D2	SELECTOR	This button is used to select the number on the numeric display (D8) the operator is willing to change. That figure blinks and can be varied working on the increase (D4) and decrease (D9) buttons.
D3	PAUSE/STAND BUTTON	Pressing this button while the appliance is working: <ul style="list-style-type: none"> - If the card is configured as "MINUTES COUNTER" the appliance stops immediately by pushing on this switch. - If the card is configured as "STROKE COUNTER" the pressing of the button stops the appliance in the moment the position sensor is activated. - The Led Pause (D5) starts lighting. - The number of strokes or the time selected during the setting up procedures are stored and saved. - The appliance also saves and stores the number of strokes made or the time gone up to that moment. - In the event that the appliance is equipped with safety guards, their opening is possible and doesn't cause the resetting.
D4	INCREASE BUTTON	It increases the value of the figure appearing on the numerical display (D8) that can be modified.
D5	LED PAUSE	When this led is lighting, the appliance is in the pause status.
D6	LED "MINUTES COUNTER"	When this led is lighting, the Stroke counter Panel is set in the "MINUTES COUNTER" mode.
D7	LED "STROKE COUNTER"	When this led is lighting, the Stroke counter Panel is set in the "STROKE COUNTER" mode.
D8	NUMERICAL DISPLAY	This allows to have all info shown about the operating of the Stroke counter Panel and also to modify the working parameters. Consult the Chapter "DISPLAY FUNCTIONS" of the present manual for further details.
D9	DECREASE BUTTON	It decreases the value of the figure appearing on the numerical display (D8) and that can be modified.
D10	STOP BUTTON	Press it to stop the appliance. The strokes counting or time counting is zeroed.
D11	START BUTTON	Press it to start the appliance.

CHAPTER 2 OPERATING

2.1 SWITCHING ON OF THE APPLIANCE

To switch on the Control Panel, put the Main Switch (D1) on the "1" position.

ATTENTION

The operator cannot choose the setting of the operating mode "STROKE COUNTER" or "MINUTES COUNTER", but it is automatically pre selected by the Manufacturer during the mounting operations.

STROKE COUNTER MODE

When the stroke counter panel is set for the STROKE COUNTER mode, the numerical display (D8) visualises the number strokes to be effected during the test execution set by the operator; this value will decrease during the working of the appliance.

In this operating mode the numbers on the display visualise the number of strokes from a minimum of 0 up to a maximum of 65.000.

When the appliance is turned on the Led (D7) turns on and the display shows the number of strokes set in the last test before its switching off.

2.2 SETTING UP OF THE STROKES NUMBER

To set the number of strokes to be effected, just enter a value from 1 to 65.000 on the numerical display (D8).

Press several times this button  until the first figure on the right starts blinking. Operate the

buttons   to set the desired value



Press the button  until the last figure but one on the right starts blinking. Operate the buttons

  to set the desired value.

Press the button  until the middle figure starts blinking. Use the buttons   to set the desired value.

Press the button  until the second figure on the left starts blinking. Use the buttons

  to set the desired value.

Press the button  until the first figure on the left starts blinking. Use the buttons  to set the desired value.

Press the button  to confirm the storing of the displayed number of strokes. To confirm the storing, the figures will stop blinking and keep lighting.

2.4 PRACTICAL EXAMPLE OF OPERATING

To start the appliance, press this button 

ATTENTION	The appliance only starts if the safety guards are correctly closed (for further details about the safety guards and the safety micro switch, consult the appliance manual or the special file regarding the Safety disposals).
------------------	---

STROKE COUNTER MODE

While the appliance is working, the numerical display (D8) shows in real time the strokes left to the end of the test. Once the set up strokes have been made, the appliance stops and the programme is now ready for a new test, always keeping the number of strokes of the previous test as valid.

NOTE	The Control Panel stops the motor only at the end of the revolution movement. It's a special position sensor, which gives the ok to the Control Panel (for further details about the Position Sensor, consult the operating manual of the appliance).
-------------	---



While the appliance is working:

Press the button  to stop the appliance while the programme gets ready for a new test. The values of the interrupted test remain set up and displayed.

- Press the button  to activate the pause function. To start the appliance again, press the button





- Press the button  to verify the number of strokes originally selected.

ATTENTION	<p>In the event of a feeding lack, the programme will keep stored either the original selected number of strokes or the number of the really effected ones up to the interruption.</p> <p>After the feeding has been activated again, the appliance will stay still displaying the</p>
	<p>number of strokes missing to end the test. Press the button  to let the appliance finish the missing strokes. If the operator prefers to start the test from the</p>
	<p>beginning, press the button  to reset the count down and then press the</p> <p>button  to start the test again.</p>

2.5 CONTROLLED ROTATION FUNCTION (TO ROTATE THE LOS ANGELES CYLINDER INTO THE REQUIRED POSITION)

	WARNING	<p>THIS FUCTION IS AVAILABLE ONLY FOR CONTROL PANEL ASSEMBLED WITH LOS ANGELES MACHINES (CODE A075) – THIS FUNCTION ALLOWS TO ROTATE THE MACHINE CYLINDER INTO THE REQUIRED POSITION IN ORDER TO LOAD OR UNLOAD THE MATERIAL</p>
---	----------------	--



Press the following buttons   multaneously; by pressing both of them, the rotation of the cylinder is activated. It will rotate until both buttons are pressed simultaneously. To interrupt the rotation, stop pressing one or both buttons.

Chapter 3 MAINTENANCE

3.1 SPECIAL MAINTENANCE

The Control Panel doesn't need a particular maintenance. In order to assure a perfect working condition, it is recommended to clean every part of the appliance from time to time. Avoid the use of solvents, which may damage the components of synthetic material.

For special maintenance operations (repair, replacement and any other operation not described in this file), contact the Manufacturer.

Recycling notice for the disposal of electrical and electronic devices



This symbol, placed on the device or on the package and/or on the documentation, suggest that the device shouldn't be dispose together with other home garbage at the end of its life cycle. To avoid further environment, or health-care damages, caused by the unsuitable disposal of garbage, we kindly recommend the user to separate this device from other different types of garbages and to recycle it in a responsible way to avoid the arguable reuse of material

resources. Indeed users must take care at the disposal of the equipment that have to be discarded, taking them away to the next recycling site for the appropriate recycling treatment for electrical and electronic devices. Gathering and Recycling deplete devices allow the preservation of natural resources and grant for them the adequate treatment respecting health and environment.

For further information about your local recycling site please contact your local city hall or city waste treatment department. The developer, as producer of electrical and electronic devices, will provide to

finance the recycling and treatment services for deplete devices that will come back through these recycling site, accordingly the local statement.

ENCLOSURE D	ELECTRIC PANEL
-------------	----------------

